

CAST IRON FLANGED SWING CHECK VALVE - PN16



Design and manufacture conforms to BS5153
 Flange dimensions conform to EN 1024-1 PN16
 Face to face dimensions conforms to BS5153 PN16
 Testing conforms to BS6755
 On special request, valve can be fitted with External Lever and Counterweight



Part N°	Part	Material	Standard
1	Bolt	Steel	BS 970 43A
2	Identification Plate	Aluminium	
3	Bonnet	Cast Iron	BS 1452 Gr220
4	Body Gasket	Graphite	
5	Nut	Steel	BS 970 43A
6	Side Plug	Brass	BS 2874 CZ122
7	Gasket	Fibre	
8	Hanger Pin	Brass	BS 2874 CZ122
9	Hanger	Ductile Iron	BS 2789 Gr420-12
10	Disc	Cast Iron	BS 1452 Gr 220
11	Disc Ring	Cast Bronze	B1400 LG2
12	Washer	Steel	BS 970 43A
13	Splt Pin	Stainless Steel	BS 970 420537
14	Disc Nut	Steel	BS 970 43A
15	Stud Bolt	Steel	BS 970 43A
16	Seat Ring	Cast Bronze	BS 1400 LG2
17	Body	Cast Iron	BS 1400 Gr220

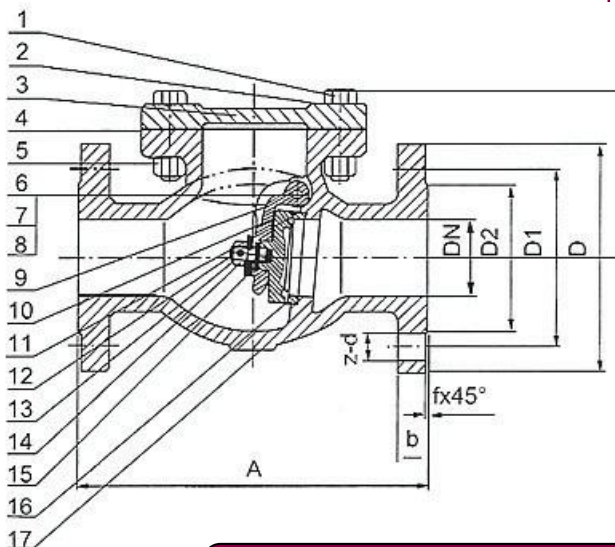

DN	A	DN	D1	D2	b	z-d	f	H
50	203	50	125	99	20	4-19	3	112.2
65	216	65	145	118	20	4-19	3	132.5
80	241	80	160	132	22	8-19	3	141.5
100	292	100	180	156	24	8-19	3	163
125	330	125	210	184	26	8-19	3	197
150	356	150	240	211	26	8-23	3	212
200	495	200	295	266	30	12-23	3	257
250	622	250	355	319	32	12-28	3	298.5
300	298	300	410	370	32	12-28	4	330.5
350	787	350	470	429	36	16-28	4	364
400	914	400	525	480	38	16-31	4	420
450	965	450	585	548	40	20-31	4	618
500	1067	500	650	609	42	20-34	4	622
600	1219	600	770	720	48	20-37	5	764



jhb@valvespec.co.za
 +27 11 397 6922

dbn@valvespec.co.za
 +27 31 569 6325

www.valvespec.co.za