

CAST IRON GATE VALVE - Rising Stem PN10

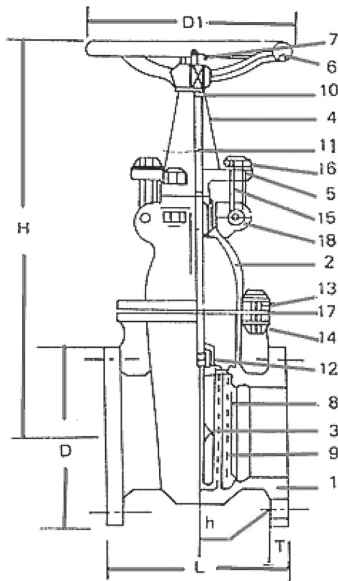

SPECIFICATIONS

- **Face-to-face dimensions**
conforms to BS 3464 / SABS 664 CL 2 (c)
- **Dimensions and drilling of end flanges**
conforms to BS 10 table E or D

PRESSURE

Primary service pressure non-shock (psi)	Hydrostatic Test Pressure (psi)	
	Shell	Seat
150	300	200

MATERIALS OF CONSTRUCTION

Part N°	Name of Part	Material
1	Body	Cast Iron
2	Bonnet	Cast Iron
3	Disc	Cast Iron
4	Yoke	Cast Iron
5	Gland Flange	Cast Iron
6	Hand Wheel	Cast Iron
7	Hand Wheel Nut	Cast Iron
8	Body Seat Ring	Cast Bronze
9	Disc Seat Ring	Cast Bronze
10	Yoke Nut	Cast Bronze
11	Stem	Stainless Steel
12	Stem Nut	Steel
13	Bonnet Bolt	Steel
14	Bonnet Nut	Steel
15	Gland Eye Bolt	Steel
16	Gland Nut	Steel
17	Bonnet Gasket	Asbestos
18	Stem Packing	Graphite

DIMENSIONS (in mm)

	Size	2	2½	3	4	5	6	8	10	12
Face-to-Face	L	146	159	165	171	190	210	241	273	305
Flange diameter	D	165	185	200	220	250	285	340	405	460
Number of Holes	N	4	4	8	8	8	8	12	12	12
Hole diameter	h	18	18	18	18	18	22	22	26	26
Flange thickness	T	18	18	20	20	22	22	24	26	28
Centre-to-top	H	315	345	392	483	569	630	777	909	1050
Wheel diameter	D1	165	165	195	242	266	292	345	376	450
Net weight	kg	16.8	18.8	21.8	33.7	45.5	59.4	90.1	146.5	224.7