

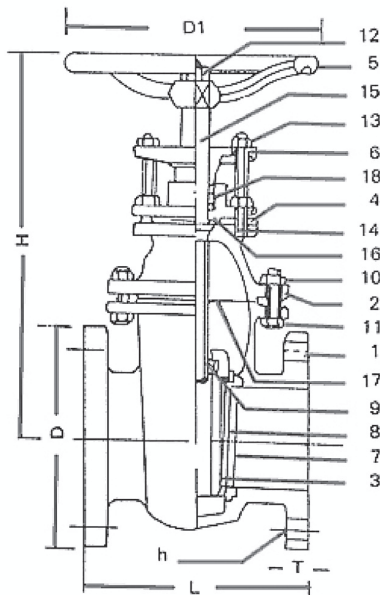

CAST IRON GATE VALVE - Non-Rising Stem PN10



SPECIFICATIONS

- **Face-to-face dimensions**
conforms to BS 3464 / SABS 664 CL 2 (c)
- **Dimensions and drilling of end flanges**
conforms to BS 10 table E or D

PRESSURE

| Primary service pressure non-shock (psi) | Hydrostatic Test Pressure (psi) | |
|---|---------------------------------|------|
| | Shell | Seat |
| 150 | 300 | 200 |

MATERIALS OF CONSTRUCTION

| Part N° | Name of Part | Material |
|---------|----------------|----------------------|
| 1 | Body | Cast Iron |
| 2 | Bonnet | Cast Iron |
| 3 | Disc | Cast Iron |
| 4 | Stuffing Box | Cast Iron |
| 5 | Hand Wheel | Cast Iron |
| 6 | Gland Flange | Cast Iron |
| 7 | Body Seat Ring | Cast Bronze |
| 8 | Disc Seat Ring | Cast Bronze |
| 9 | Disc Nut | Cast Bronze |
| 10 | Bonnet Nut | Steel |
| 11 | Bonnet Bolt | Steel |
| 12 | Wheel Nut | Steel |
| 13 | Gland Bolt Nut | Steel |
| 14 | Gland Bolt | Steel |
| 15 | Stem | Stainless Steel |
| 16 | Gasket | Asbestos Joint Sheet |
| 17 | Gasket | Asbestos Joint Sheet |
| 18 | Gland Packing | Asbestos Graphite |

DIMENSIONS (in mm)

| | Size | 2 | 2½ | 3 | 4 | 5 | 6 | 8 | 10 | 12 |
|------------------|------|------|------|-----|-----|-----|-----|-----|-----|-----|
| Mark | | | | | | | | | | |
| Face-to-Face | L | 146 | 159 | 165 | 171 | 190 | 210 | 241 | 273 | 305 |
| Flange diameter | D | 165 | 185 | 200 | 220 | 250 | 285 | 340 | 405 | 460 |
| Number of Holes | N | 4 | 4 | 8 | 8 | 8 | 8 | 12 | 12 | 12 |
| Hole diameter | h | 18 | 18 | 18 | 18 | 18 | 22 | 22 | 26 | 26 |
| Flange thickness | T | 18 | 18 | 20 | 20 | 22 | 22 | 24 | 26 | 28 |
| Centre-to-top | H | 252 | 270 | 308 | 367 | 433 | 486 | 588 | 697 | 792 |
| Wheel diameter | D1 | 165 | 165 | 165 | 242 | 266 | 345 | 345 | 376 | 450 |
| Net weight | kg | 14.0 | 17.0 | 20 | 28 | 39 | 51 | 79 | 136 | 185 |